

**OUTLET**  
POLYLOK III SEAL  
RUBBER BOOT  
ACCEPTS 3" & 4"  
PIPE

- NOTES:**
1. CONCRETE TO BE MINIMUM 32 MPA 5-8% AIR ENTRAINMENT
  2. TANK BODY: ENDURO STRUCTURAL FIBER BOND ADDED TO CONCRETE  
1 PUCK/CU/FT, 1 PUCK = 63.5 GRAMS (2.24 OZ), STRANDS = 2 in LENGTH (50mm)
  3. WEIGHTS: LID ONLY 1600 lbs/726 kg, TANK BODY 9400 lbs/4264 kg, TOTAL WEIGHT 11,000 lbs/4990 kg

**PLAN VIEW**

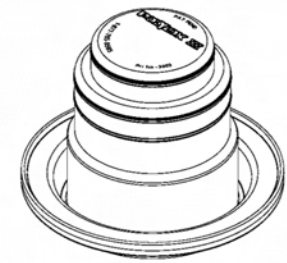
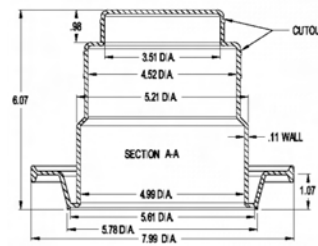

POLYLOK TYPE III SEAL  
PART NO. 3003-B  
MATERIAL - RUBBER  
PRODUCT IS SUPPLIED WITH SS HOSE CLAMP

**INLET**  
POLYLOK III SEAL  
RUBBER BOOT  
ACCEPTS 3" & 4" PIPE

**POLYLOK TYPE III SEAL**

**LID:** 6"x6" 10/10 GAUGE MESH  
LAYS BELOW 10mm REBAR  
ON 6" CENTRES EACH WAY  
STEEL IS 25mm OFF BOTTOM

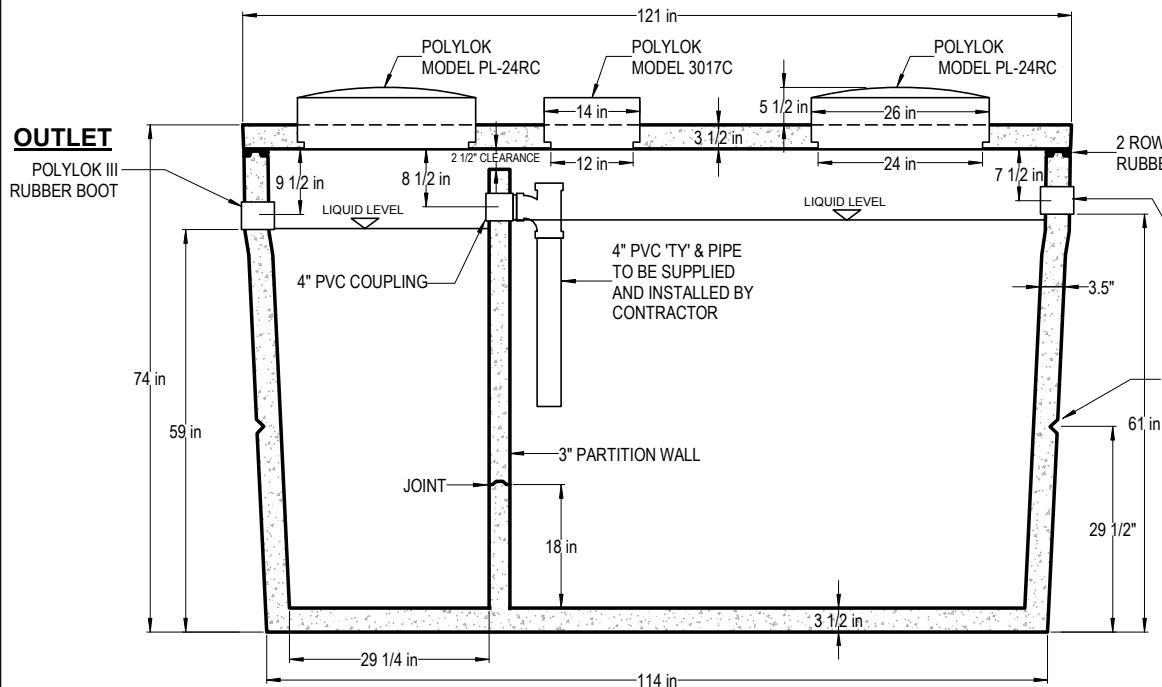

**OUTLET**  
POLYLOK III  
RUBBER BOOT

**INLET**  
POLYLOK III  
RUBBER BOOT

**SIDE ELEVATION - SECTION A-A**

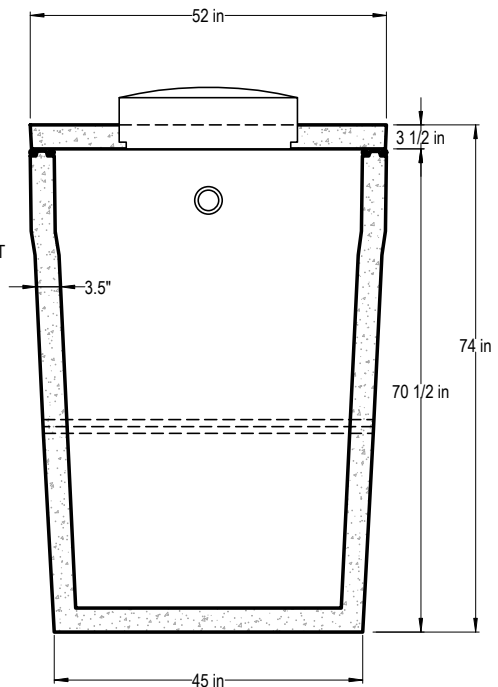

**END ELEVATION SECTION B-B**

601 Patterson West  
Cranbrook, B.C.  
PO BOX 491 VIC 4J6  
Phone 250-426-8162  
Fax 250-489-4013  
email: info@trikonprecast.com  
www.trikonprecast.com



**900 GALLON SEPTIC TANK**

NOT TO SCALE

APRIL 19/2006

DRAWN: RAB

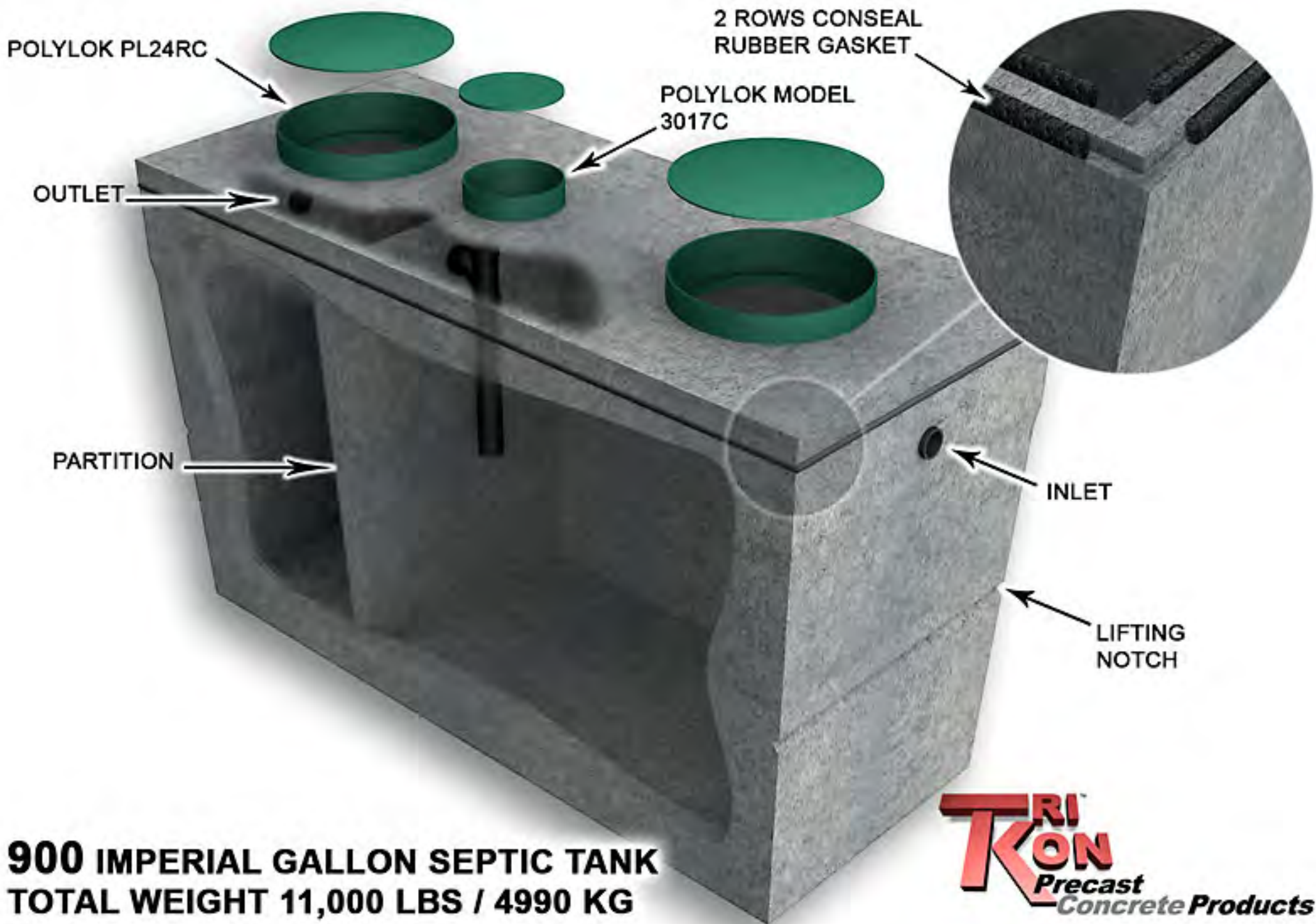

**900 IMPERIAL GALLON SEPTIC TANK**  
**TOTAL WEIGHT 11,000 LBS / 4990 KG**

**TRIKON**  
*Precast*  
*Concrete Products*